

Shrouded Drinking Fountain With WRAS Approved Bubbler

Product Code DFWHS-WRAS

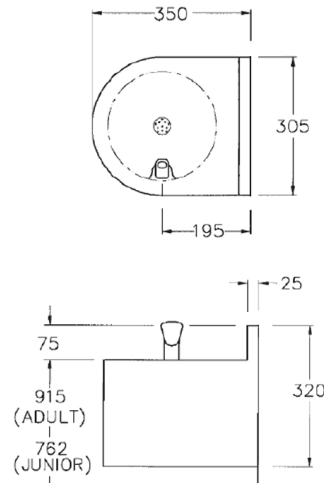

Material:

The wall mounted shrouded drinking fountain is manufactured from 1.6 thick satin polished stainless steel for durability and vandal resistance. Supplied with WRAS approved drinking water bubbler (tap). WRAS is the Water Regulations Advisory Scheme and the water bubbler (tap) has been tested and approved to meet the water byelaws.

Design:

The drinking fountain and undershroud has a radius front design to eliminate sharp corners and edges which makes it suitable for use in school and public buildings. The unit incorporates integral wall fixing brackets which allow the drinking fountain to be easily installed at adult or junior height. The undershroud has a removable access panel held in place with security screws.

Fittings:

The drinking fountain comes complete with integral wall fixing brackets, 32mm flush grated waste fitting, and WRAS approved chrome plated bubbler valve.

Options:

32mm plastic bottle trap.

Alternative Models Available:

- Wall mounted drinking fountain.
- Floor standing junior height drinking fountain.
- Floor standing adult height drinking fountain.
- Floor standing pedestal drinking fountain.
- Recessed drinking fountain.
- Combined drinking fountain and bottle filling station.